

# HP2403

## High Efficiency DC\DC Power Module

### FEATURES:

- High Power Density Power Module
- Standard DOSA footprint
- Maximum Load:20A
- Input Voltage Range from 4.5V to 14.5V
- Output Voltage Range from 0.6V to 5.0V
- 97% Peak Efficiency
- Voltage Mode Control
- Protections (OCP, UVP, OTP, Non-latching)
- Internal Soft Start
- Pre-Biased Output
- Fixed Switching Frequency of 600kHz
- Power Good Indication
- Small size and low profile  
(12.19mm x 12.19mm x 8.4mm)
- Negative / Positive on/off logic
- Pb-free Available (RoHS compliant)
- MSL 2a, 245°C Reflow
- Compliant to IPC-9592 (September 2008)

### APPLICATIONS:

- General Buck DC/DC Conversion
- DC Distributed Power System
- Telecom and Networking Equipments
- Servers System

### GENERAL DESCRIPTION:

The HP2403 is a high frequency, high power density and complete DC/DC power module. The PWM controller, power MOSFETs and most of support components are integrated in one hybrid package. Additional, a new patent technology is adopted to stack power choke on the hybrid module in order to achieve high power density.

The features of HP2403 include voltage mode control with high phase margin compensation, internal soft start, protections, and pre-biased output function. Besides, HP2403 is an easy to use DC/DC power module, it only needs input/output capacitors and one voltage dividing resistor to perform properly.

The low profile and compact size enables utilization of space on the bottom or top of PC boards either for highly density point of load regulation to save the space and area. It is suitable for automated assembly by standard surface mount equipment and complies with Pb-free and RoHS compliance.

### TYPICAL APPLICATION CIRCUIT & PACKAGE SIZE:

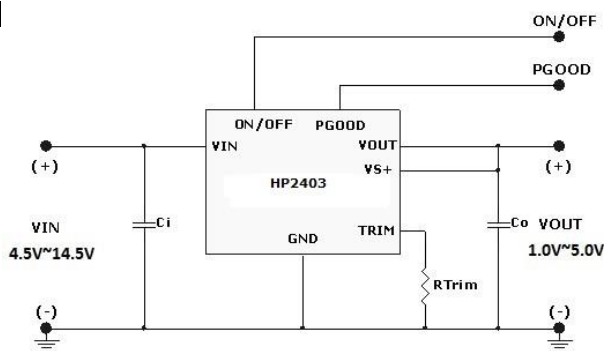

FIGURE.1 TYPICAL APPLICATION CIRCUIT

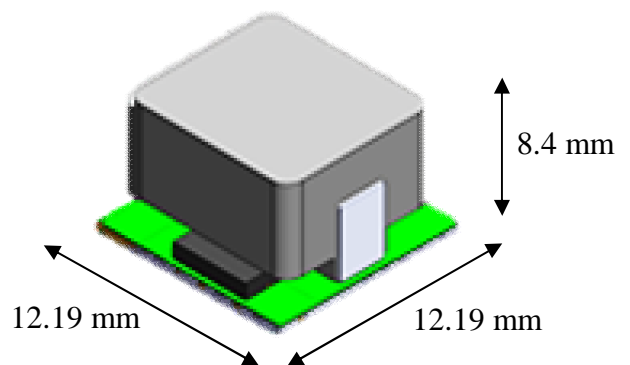

FIGURE.2 HIGH DENSITY POWER MODULE

# HP2403

## High Efficiency DC\DC Power Module

### ELECTRICAL SPECIFICATIONS:

CAUTION: Do not operate at or near absolute maximum rating listed for extended periods of time. This stress may adversely impact product reliability and result in failures outside of warranty.

Parameter	Description	Min.	Typ.	Max.	Unit
■ Absolute Maximum Ratings					
VIN to GND	Continuous	-0.3	-	+16.0	V
ON/OFF to GND		-0.3	-	+7.0	V
VS+ to GND		-0.3	-	+7.0	V
TRIM to GND		-0.3	-	+7.0	V
PGOOD to GND		-0.3	-	+7.0	V
Tc		-	-	+110	°C
Tj		-40	-	+125	°C
Tstg		-40	-	+125	°C
ESD Rating	Human Body Model (HBM)	-	-	2k	V
	Machine Model (MM)	-	-	100	V
	Charge Device Model (CDM)	-	-	1k	V
■ Thermal Information					
Rth(jchoke-a)	Thermal resistance from junction to ambient.	-	15	-	°C/W
■ Recommendation Operating Ratings					
VIN	Input Supply Voltage	+4.5	-	+14.5	V
VOUT	Adjusted Output Voltage	+0.6	-	+5.0	V
Ta	Ambient Temperature	-40	-	+85	°C

#### NOTES:

- Parameters guaranteed and tested by power IC vendor.
- Rth(jchoke-a) is measured with the component mounted on an effective thermal conductivity test board on 0 LFM condition. The test board size is 80mm×80mm×1.6mm with 4 layers. The test condition is complied with JEDEC EIJ/JESD 51 Standards.

# HP2403

## High Efficiency DC\DC Power Module

### ELECTRICAL SPECIFICATIONS: (Cont.)

Conditions:  $T_A = 25\text{ }^\circ\text{C}$ , unless otherwise specified.

$V_{in}=12\text{V}$ ,  $V_{out}=3.3\text{V}$ ,  $C_{in}=22\mu\text{F}/\text{Ceramic}\times 3$ ,  $C_{out}=47\mu\text{F}/\text{Ceramic}\times 4 + \text{POScap LOW ESR } 330\mu\text{F}$

Symbol	Parameter	Conditions	Min.	Typ.	Max.	Unit
<b>■ Input Characteristics</b>						
$I_{Q(VIN)}$	Input supply bias current	$I_{out} = 0\text{A}$ $V_{in} = 12\text{V}$ , $V_{out} = 3.3\text{V}$	-	75	-	mA
$I_{S(VIN)}$	Input supply current	$I_{out} = 20\text{A}$ $V_{in} = 12\text{V}$ , $V_{out} = 3.3\text{V}$	-	5.8	-	A
<b>■ Output Characteristics</b>						
$I_{OUT(DC)}$	Output continuous current range	$V_{in}=12\text{V}$ , $V_{out}=3.3\text{V}$	0	-	20	A
$\Delta V_{OUT}/\Delta V_{IN}$	Line regulation accuracy	$V_{in} = 10.8\text{V}$ to $13.2\text{V}$ $V_{out} = 3.3\text{V}$ , $I_{out} = 0\text{A}$ $V_{out} = 3.3\text{V}$ , $I_{out} = 20\text{A}$	-	0.3	-	%
$\Delta V_{OUT}/\Delta I_{OUT}$	Load regulation accuracy	$I_{out} = 0\text{A}$ to $20\text{A}$ $V_{in} = 12\text{V}$ , $V_{out} = 3.3\text{V}$	-	0.5	-	%
$V_{OUT(AC)}$	Output ripple voltage	$I_{out} = 20\text{A}$ $V_{in} = 12\text{V}$ , $V_{out} = 3.3\text{V}$	-	25	35	mVp-p
$V_{o, set}$	Output voltage set point	$T_J = 25\text{ }^\circ\text{C}$ , with 0.5% tolerance for external resistor used to set output voltage	-1.0		+1.0	% $V_{o, set}$
<b>■ Dynamic Characteristics</b>						
$\Delta V_{OUT-DP}$	Voltage change for positive load step	$I_{out} = 10\text{A}$ to $20\text{A}$ Current slew rate = $2.5\text{A}/\mu\text{s}$ $V_{in} = 12\text{V}$ , $V_{out} = 3.3\text{V}$	-	100	150	mVp-p
$\Delta V_{OUT-DN}$	Voltage change for negative load step	$I_{out} = 10\text{A}$ to $20\text{A}$ Current slew rate = $2.5\text{A}/\mu\text{s}$ $V_{in} = 12\text{V}$ , $V_{out} = 3.3\text{V}$	-	100	150	mVp-p
<b>■ Control Characteristics</b>						
$V_{REF}$	Reference voltage	$T_J = 25\text{ }^\circ\text{C}$	0.597	0.6	0.603	V
		$-40\text{ }^\circ\text{C} < T_J < 125\text{ }^\circ\text{C}$	0.594	0.6	0.606	
$F_{OSC}$	Oscillator frequency		540	600	660	kHz
$V_{UV}$	Feedback lower voltage limit for PGOOD		0.500	0.525	0.550	V
$V_{OV}$	Feedback upper voltage limit for PGOOD		0.655	0.675	0.700	V
<b>■ ON-OFF Control, (Negative logic)</b>						
Von/off	Logic Low Voltage	Module On	-0.2	-	0.8	V
Von/off	Logic High Voltage	Module Off	3.0	-	$V_{IN}$	V
Ion/off	Logic Low Current	Module On		-	10	$\mu\text{A}$
Ion/off	Logic High Current	Module Off		-	1	mA

# HP2403

## High Efficiency DC\DC Power Module

### ELECTRICAL SPECIFICATIONS: (Cont.)

Conditions:  $T_A = 25\text{ }^\circ\text{C}$ , unless otherwise specified.

$V_{in}=12\text{V}$ ,  $V_{out}=3.3\text{V}$ ,  $C_{in}=22\mu\text{F/Ceramic}\times 3$ ,  $C_{out}=47\mu\text{F/Ceramic}\times 4 + \text{POScap LOW ESR } 330\mu\text{F}$

Symbol	Parameter	Conditions	Min.	Typ.	Max.	Unit
<b>■ Efficiency</b>						
$\eta$	Efficiency	$V_{IN}=12\text{V}$ , $V_{OUT}=1.0\text{V}$ , $I_{OUT}=20\text{A}$		86.6		%
$\eta$	Efficiency	$V_{IN}=12\text{V}$ , $V_{OUT}=1.2\text{V}$ , $I_{OUT}=20\text{A}$		88.3		%
$\eta$	Efficiency	$V_{IN}=12\text{V}$ , $V_{OUT}=1.8\text{V}$ , $I_{OUT}=20\text{A}$		91.5		%
$\eta$	Efficiency	$V_{IN}=12\text{V}$ , $V_{OUT}=2.5\text{V}$ , $I_{OUT}=20\text{A}$		93.2		%
$\eta$	Efficiency	$V_{IN}=12\text{V}$ , $V_{OUT}=3.3\text{V}$ , $I_{OUT}=20\text{A}$		94.4		%
$\eta$	Efficiency	$V_{IN}=12\text{V}$ , $V_{OUT}=5.0\text{V}$ , $I_{OUT}=20\text{A}$		95.8		%
<b>■ PWM</b>						
$D_{MAX}$	Maximum duty cycle		90%			
$T_{ON(min)}$	Minimum controllable pulse width				70	ns
<b>■ Fault Protection</b>						
$T_{TSD}$	Shutdown temperature	Note 3 ( $T_j$ of internal PWM IC)		145		$^\circ\text{C}$

#### NOTES:

- Parameters guaranteed by PWM IC vendor design and test prior to module assembly.

# HP2403

## High Efficiency DC\DC Power Module

### PIN CONFIGURATION:

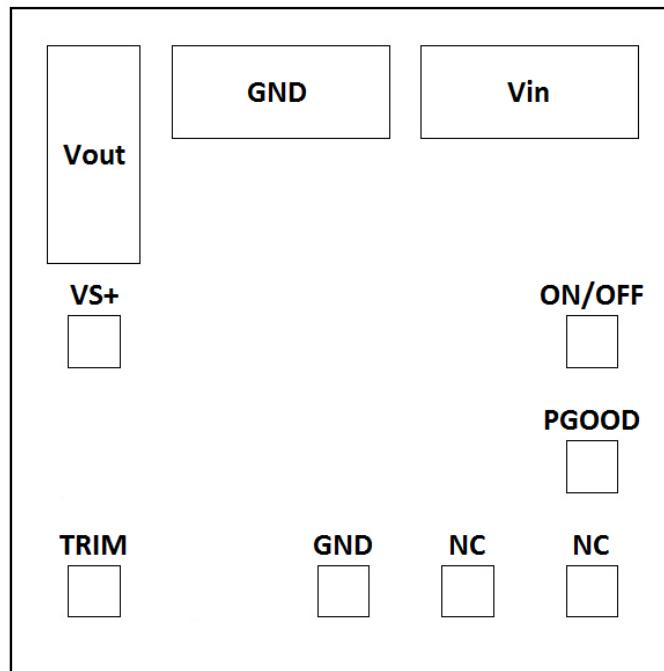

Bottom View

### PIN DESCRIPTION:

Symbol	Pin No.	Description
ON/OFF	1	Enable – to pull the pin lower than 0.8V Disable – to float the pin or pull the pin higher than 3.0V
VIN	2	Power input pin. It needs to be connected to input rail. It also needs to be connected to thermal dissipation layer by vias connection.
GND	3、7	All voltage levels are referenced to the pins. All pins should be connected together with a ground plane
VOUT	4	Power output pin. It needs to be connected to output rail. It also needs to be connected to thermal dissipation layer by vias connection.
VS+(SENSE)	5	Output voltage sensing pin. Connect to output loading to eliminate the positive voltage loss along the trace and keep the regulation at loading. CAUTION: Do not leave this pin open.
TRIM	6	Feedback input. Connect a resistor between this pin and ground for adjusting output voltage. Place this resistor as closely as possible to this pin and ground.
NC	8、9	No connect
PGOOD	10	This is an open drain signal and pulls low when any condition exists that would indicate that the output of the supply might be out of regulation. An external pull-up resistor 50kohm should be connected to a supply +5V.

# HP2403

## High Efficiency DC\DC Power Module

### TYPICAL PERFORMANCE CHARACTERISTICS: (VOUT=1.0V)

Conditions: Cin=22uF/Ceramic×3, Cout=47uF/Ceramic×4 + POScap LOW ESR 330uF. Test Board Information: 80mm×80mm×1.74mm, 4 layers.

**NOTES:**

The output ripple and transient response are measured by short loop probing and limited to 20MHz bandwidth. The following figures are the typical characteristic curves at 1.0Vout.

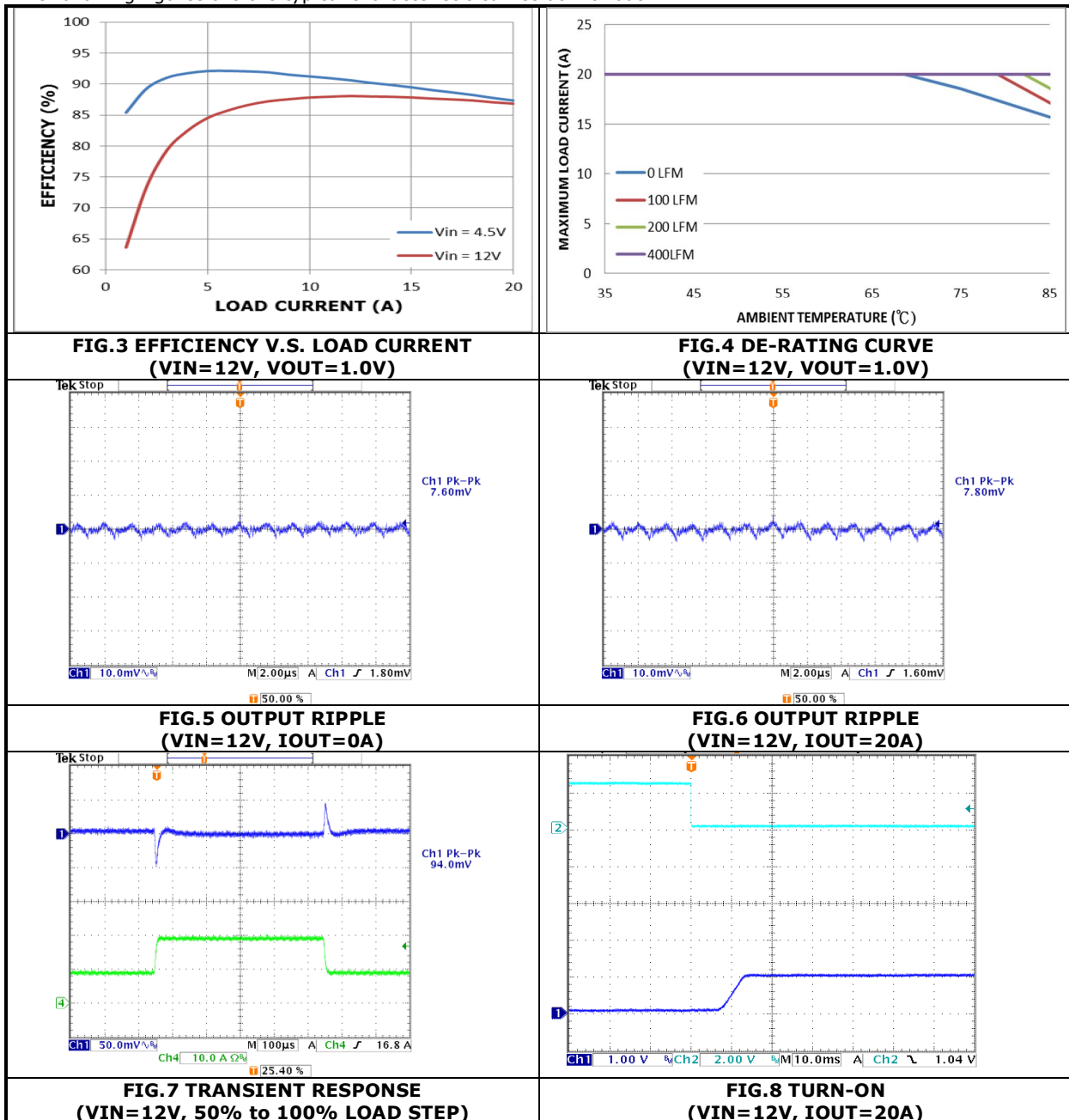

# HP2403

## High Efficiency DC\DC Power Module

### TYPICAL PERFORMANCE CHARACTERISTICS: (VOUT=1.2V)

Conditions: Cin=22uF/Ceramic×3, Cout=47uF/Ceramic×4 + POScap LOW ESR 330uF. Test Board Information: 80mm×80mm×1.6mm, 4 layers.

**NOTES:**

The output ripple and transient response are measured by short loop probing and limited to 20MHz bandwidth. The following figures are the typical characteristic curves at 1.2Vout.

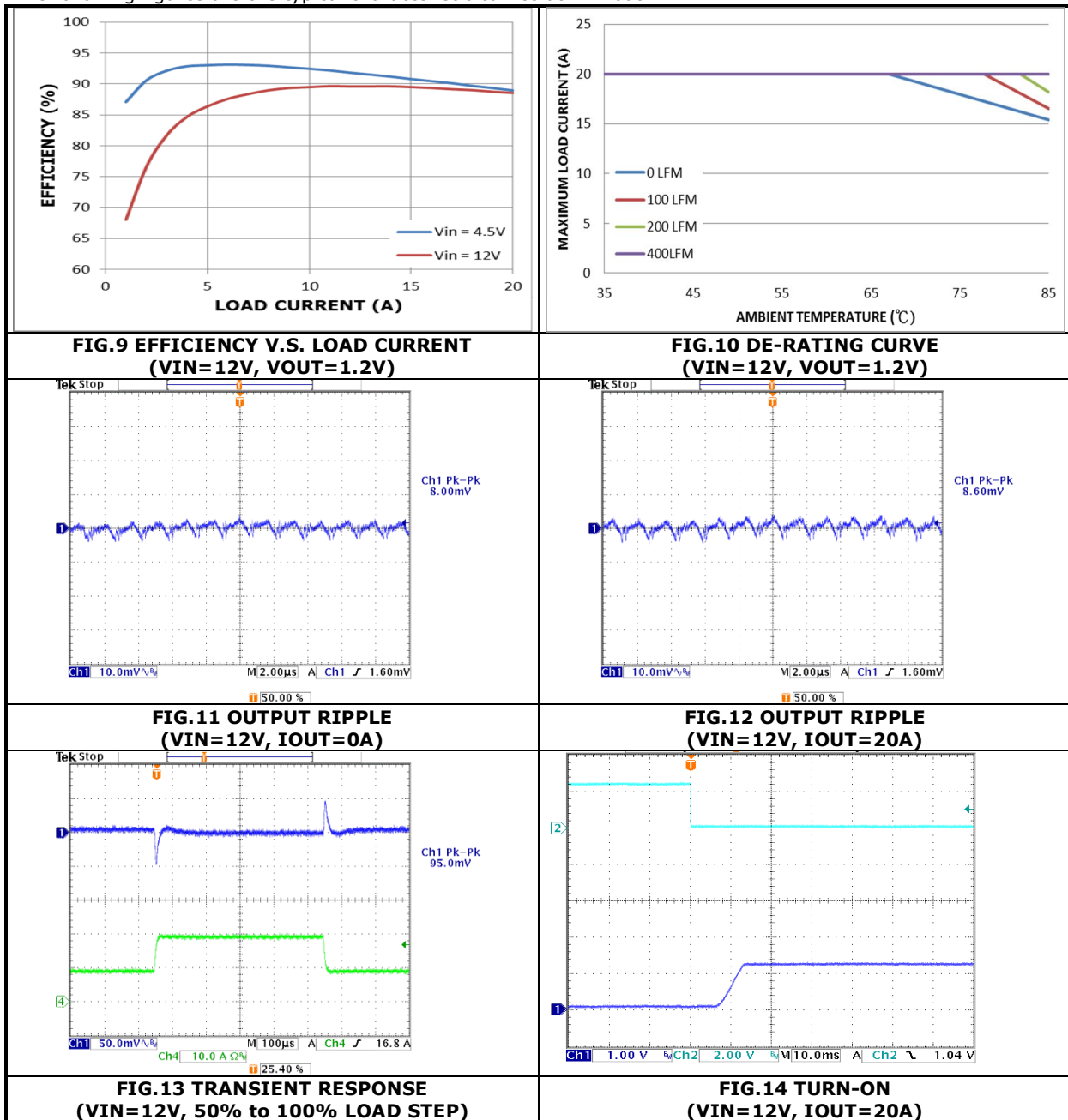

# HP2403

## High Efficiency DC\DC Power Module

### TYPICAL PERFORMANCE CHARACTERISTICS: (VOUT=1.8V)

Conditions: Cin=22uF/Ceramic×3, Cout=47uF/Ceramic×4 + POScap LOW ESR 330uF. Test Board Information: 80mm×80mm×1.6mm, 4 layers.

**NOTES:**

The output ripple and transient response are measured by short loop probing and limited to 20MHz bandwidth. The following figures are the typical characteristic curves at 1.8Vout.

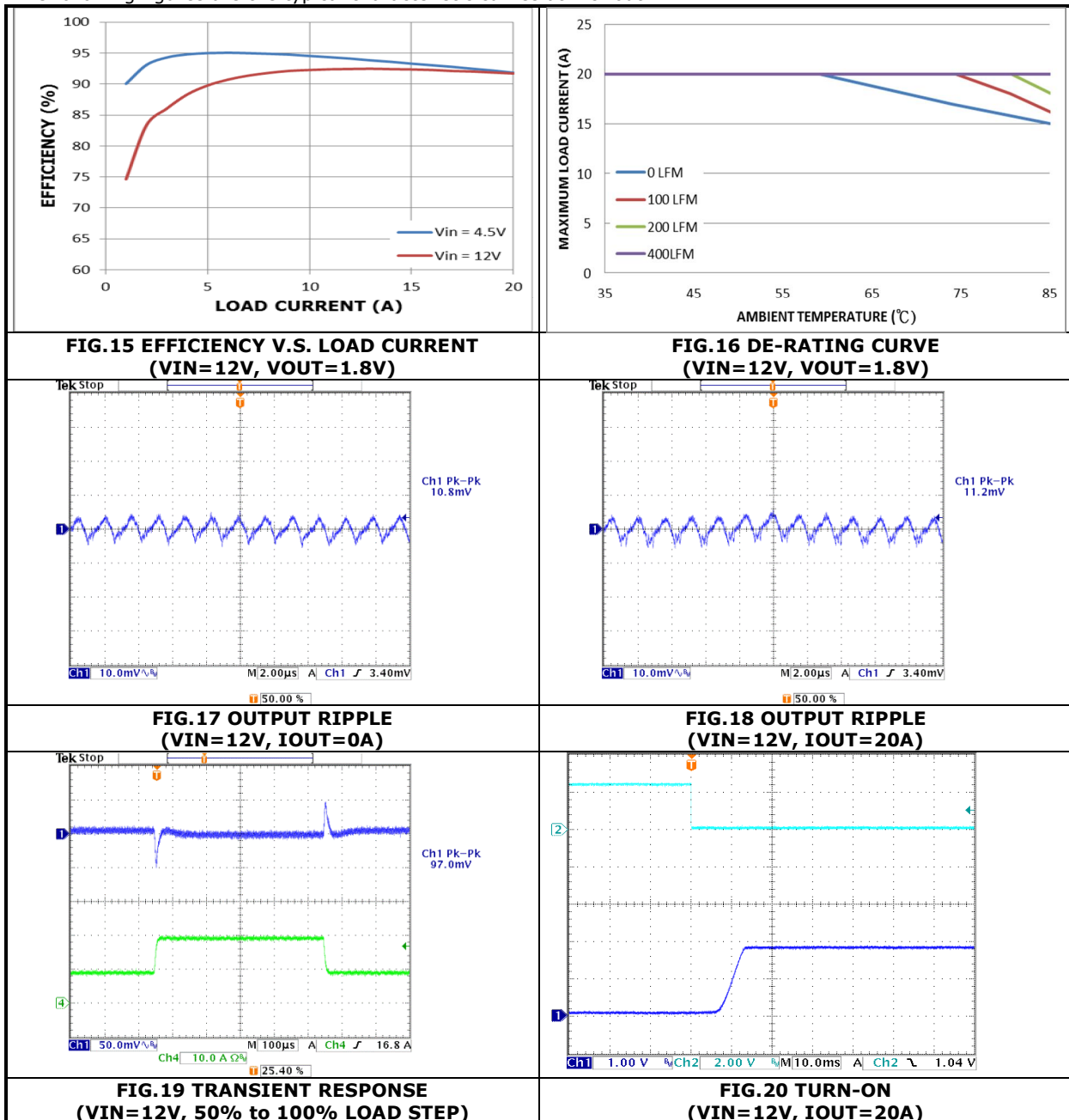



# HP2403

## High Efficiency DC\DC Power Module

### TYPICAL PERFORMANCE CHARACTERISTICS: (VOUT=2.5V)

Conditions: Cin=22uF/Ceramic×3, Cout=47uF/Ceramic×4 + POScap LOW ESR 330uF. Test Board Information: 80mm×80mm×1.6mm, 4 layers.

**NOTES:**

The output ripple and transient response are measured by short loop probing and limited to 20MHz bandwidth. The following figures are the typical characteristic curves at 2.5Vout.

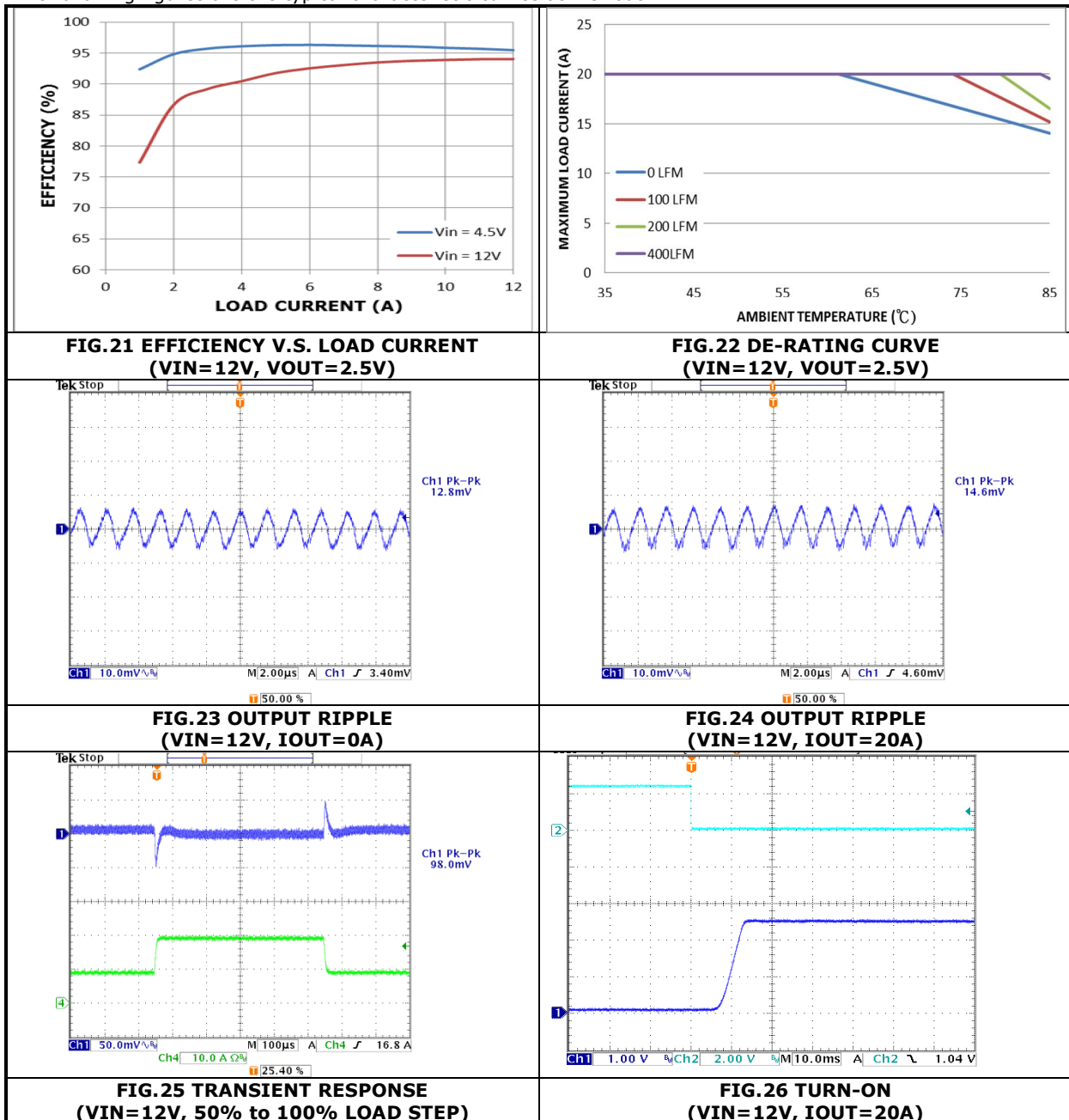

# HP2403

## High Efficiency DC\DC Power Module

### TYPICAL PERFORMANCE CHARACTERISTICS: (VOUT=3.3V)

Conditions: Cin=22uF/Ceramic×3, Cout=47uF/Ceramic×4 + POScap LOW ESR 330uF. Test Board Information: 80mm×80mm×1.6mm, 4 layers.

**NOTES:**

The output ripple and transient response are measured by short loop probing and limited to 20MHz bandwidth. The following figures are the typical characteristic curves at 3.3Vout.

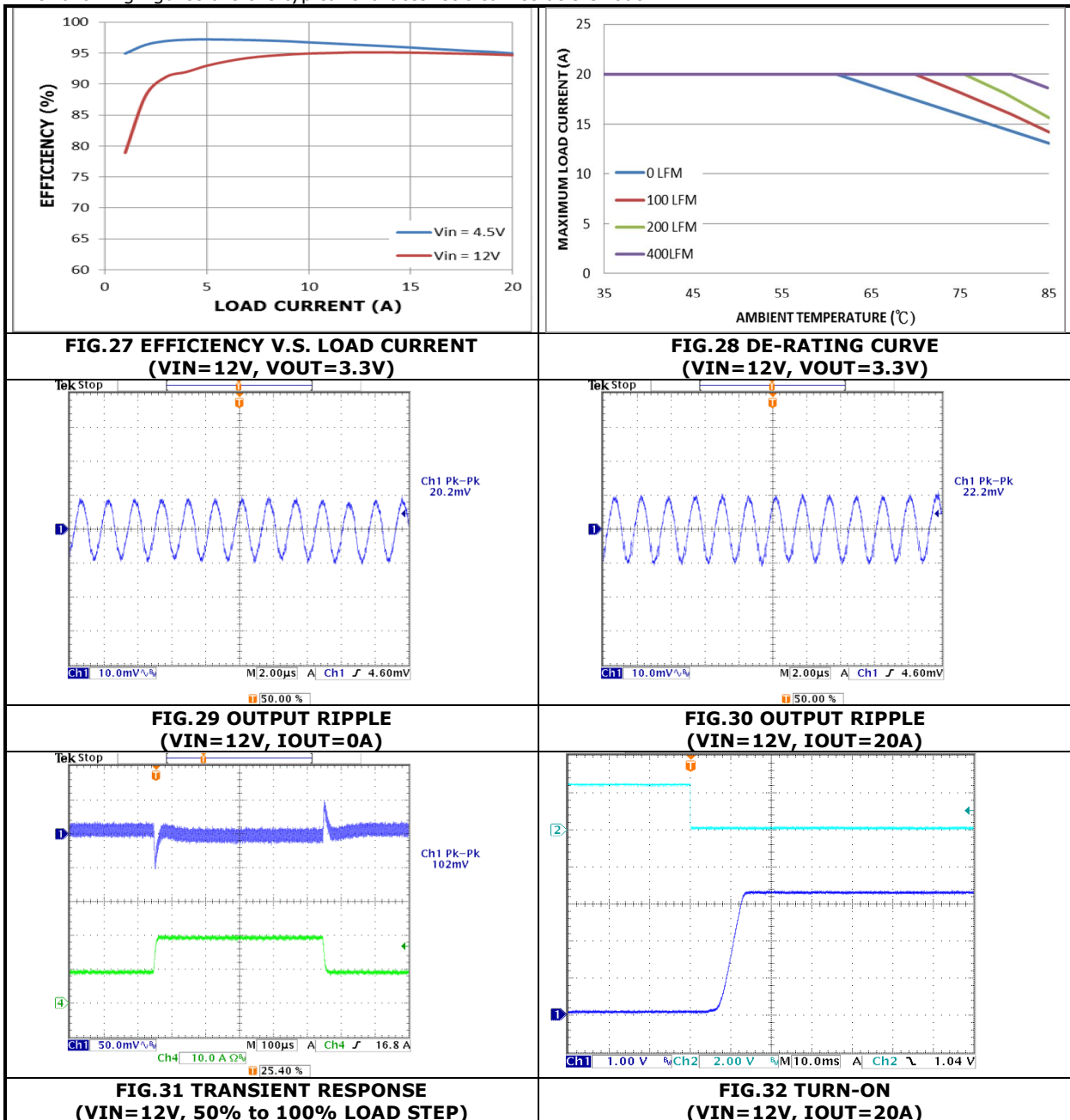

# HP2403

## High Efficiency DC\DC Power Module

### TYPICAL PERFORMANCE CHARACTERISTICS: (VOUT=5.0V)

Conditions: Cin=22uF/Ceramic×3, Cout=47uF/Ceramic×4 + POScap LOW ESR 330uF. Test Board Information: 80mm×80mm×1.6mm, 4 layers.

**NOTES:**

The output ripple and transient response are measured by short loop probing and limited to 20MHz bandwidth. The following figures are the typical characteristic curves at 5.0Vout.

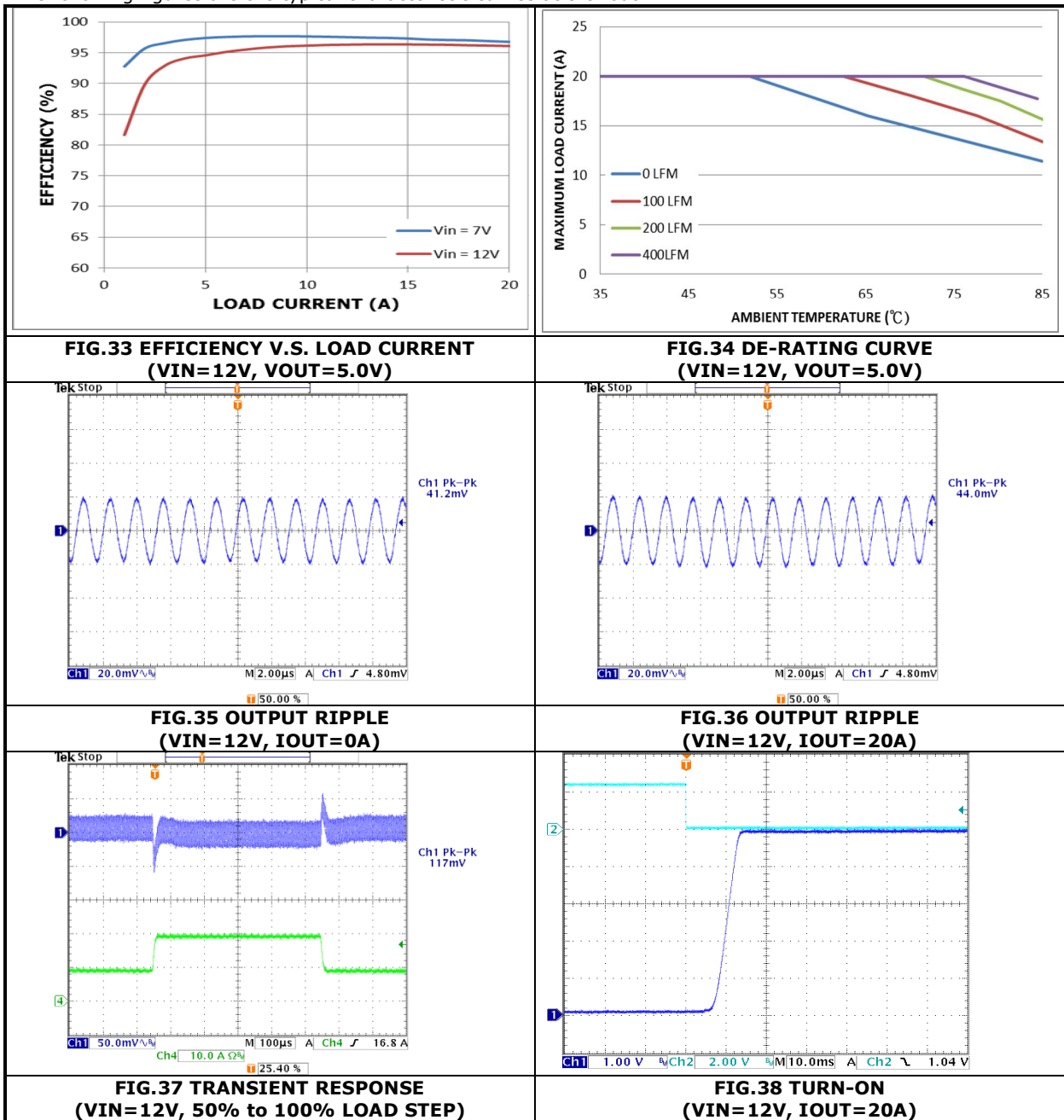

# HP2403

## High Efficiency DC\DC Power Module

### APPLICATIONS INFORMATION:

#### REFERENCE CIRCUIT FOR GENERAL APPLICATION:

The FIG. 39 shows the HP2403 application schematics for input voltage +12V.

Condition:

$V_{IN} = 12V$  ,  $V_{OUT} = 1.8V$  ,  $I_{OUT} = 20A$

$C_{i1} = 3 \times 22\mu F / 25V$  ,  $C_{o1} = 330\mu F / 6.3V$  ,  $C_{o2} = 4 \times 47\mu F / 6.3V$

$R_{Trim} = 5k \text{ ohm}$

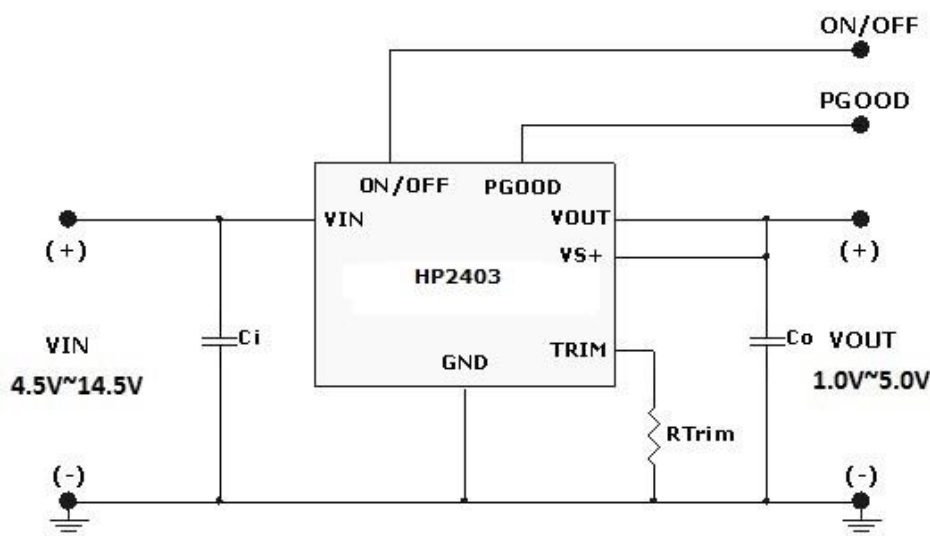

FIG.39 TYPICAL APPLICATION CIRCUIT

### Safety Consideration

Certain applications and/or safety agencies may require fuses at the inputs of power conversion components. Fuses should also be used when there is the possibility of sustained input voltage reversal which is not current limited. For greatest safety, we recommend a fast blow fuse installed in the ungrounded input supply line. The installer must observe all relevant safety standards and regulations. For safety agency approvals, install the converter in compliance with the end-user safety standard.

### INPUT FILTERING:

The module should be contacted to as low AC impedance source supply and a highly inductive source or line inductance can affect the stability of the module. An input capacitor must be placed directly to the input pin of the module, to minimize input ripple voltage and ensure module stability.

# HP2403

## High Efficiency DC\DC Power Module

### APPLICATIONS INFORMATION: (Cont.)

#### OUTPUT FILTERING:

To reduce output ripple and improve the dynamic response to as step load change, the additional capacitor at the output must be used. Low ESR polymer and ceramic capacitors are recommended to improve the output ripple and dynamic response of the module.

#### Pre-Bias Startup:

The HP2403 contains a circuit to prevent current from being pulled from the output during startup in the condition the output is pre-biased. There are on PWM pulses until the internal soft-start voltage rises above the error amplifier input, if the output is pre-biased. Once the soft-start voltage exceeds the error amplifier input, the controller slowly initiates synchronous rectification by starting the synchronous rectifier with narrow on time. It then increments that on time on a cycle-by-cycle basis until it coincides with the time dictated by  $(1-D)$ , where the  $D$  is duty cycle of the converter. This approach prevents the sinking of current from a pre-biased output, and ensures the output voltage startup and ramp to regulation is smooth and controlled.

#### Power Good:

The HP2403 provides an indication that output is good for the converter. This is an open drain signal and pulls low if any condition exists such as  $V_{TRIM}$  is more than  $\pm 12.5\%$  from nominal, soft-start is active, and short circuit condition has been detected. The PGOOD terminal should be connected through a pull up resistor (suggested value is 50Kohm) to a source of 5VDC.

#### Overcurrent Protection:

The over-current function protects the converter from a shorted output by using the low side MOSFET on-resistance,  $R_{DS(ON)}$ , to monitor the current. When the protection is triggered, the module enters hiccup mode. The module operates normally once the fault is removed.

#### Over Temperature Protection:

If the junction temperature of the HP2403 reaches the thermal shutdown limit of  $145^{\circ}\text{C}$ , the PWM and the oscillator are turned off and H/L MOSFET are driven low. When the junction cools to the required level ( $125^{\circ}\text{C}$  typical), the PWM initiates soft start as during a normal power up cycle.

# HP2403

## High Efficiency DC\DC Power Module

### APPLICATIONS INFORMATION: (Cont.)

#### Remote Sense:

The power module has a Remote Sense feature to eliminate the distribution losses on the output line trace and keep the regulation at loading point. In the event of an open remote sense line, the module shall maintain local sense regulation through an internal resistor.

#### Remote ON/OFF:

The HP2403 power module has an ON/OFF pin for remote ON/OFF operation. Both positive and negative ON/OFF logic options are available.

For negative logic option, the circuit configuration is shown in FIG.40. The ON/OFF pin should be pull high with an external pull-up resistor (suggested value is 50k ohm for 4.5V to 14.5V input range). When the Q1 is in the OFF state, the ON/OFF pin is pulled high and the module is OFF. To turn the module ON, Q1 is turned ON pulling the ON/OFF pin low.

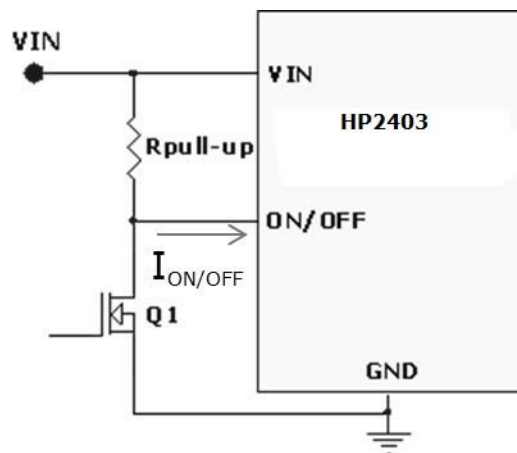

FIG.40 CIRCUIT FOR NEGATIVE ON/OFF LOGIC

# HP2403

## High Efficiency DC\DC Power Module

### APPLICATIONS INFORMATION: (Cont.)

#### Output Voltage Programming:

The HP2403 has an internal 0.6V reference voltage, It only programs the dividing resistance  $R_{TRIM}$  which respects to TRIM pin and GND. The output voltage can be calculated as shown in Equation 1 and the resistance according to typical output voltage is shown in TABLE 1.

(Note : internal resistance was 10k ohm  $\pm$  0.5%)

$$V_{OUT} = 0.6 \times \left( 1 + \frac{10k}{R_{TRIM}} \right) \quad (EQ.1)$$

VOUT	1.0V	1.2V	1.5V	1.8V	2.5V	3.3V	5V
RTrim(ohm)	15k	10k	6.667k	5k	3.158k	2.222k	1.364k

TABLE 1

# HP2403

## High Efficiency DC\DC Power Module

### APPLICATIONS INFORMATION: (Cont.)

#### Thermal Considerations:

All of thermal testing condition is complied with JEDEC EIJ/JESD 51 Standards. Therefore, the test board size is 80mm×80mm×1.6mm with 4 layers. The case temperature of module sensing point is shown as Figure 41. Then  $R_{th(j_{choke}-a)}$  is measured with the component mounted on an effective thermal conductivity test board on 0 LFM condition. The HP2403 module is designed for using when the case temperature is below 110°C regardless the change of output current, input/output voltage or ambient temperature.

Sensing point(Defined case temperature)

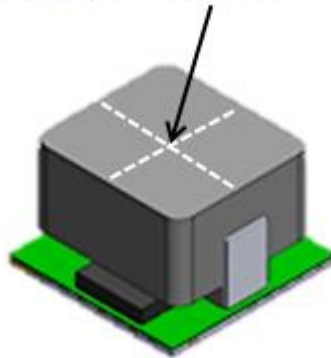

Figure 41. Case Temperature Sensing Point



# HP2403

## High Efficiency DC\DC Power Module

### PACKAGE OUTLINE DRAWING:

Unit: mm

General Tolerances:  $\pm 0.2$ mm

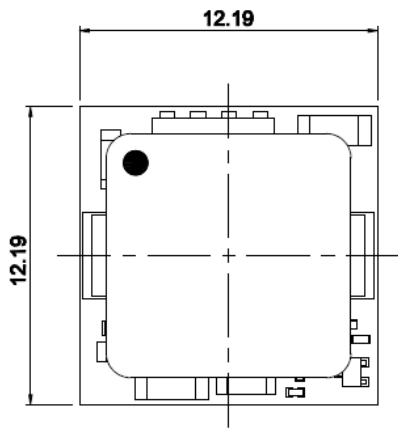

TOP VIEW

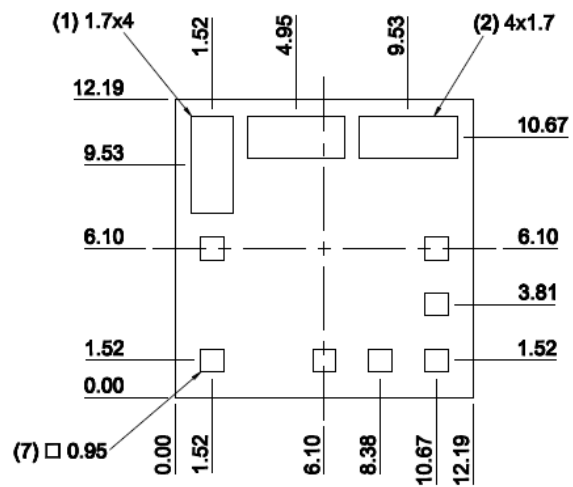

BOTTOM VIEW

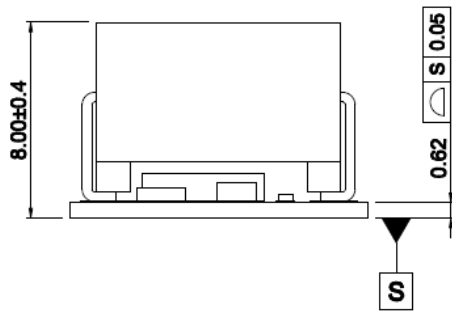

SIDE VIEW

# HP2403

## High Efficiency DC\DC Power Module

### LAND PATTERN REFERENCE:

Unit: mm

General Tolerances:  $\pm 0.2$ mm

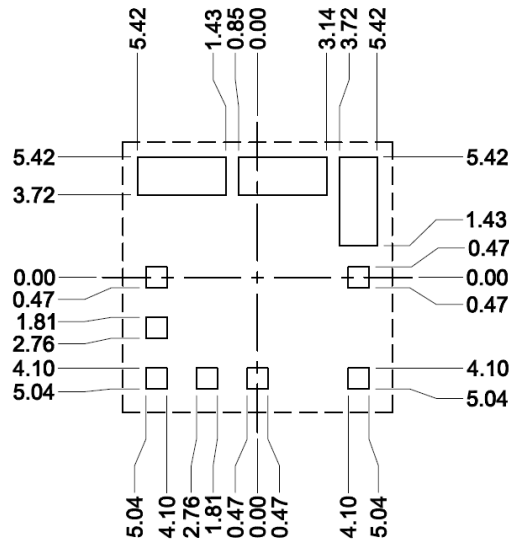

TOP VIEW

TYPICAL RECOMMENDED LAND PATTERN

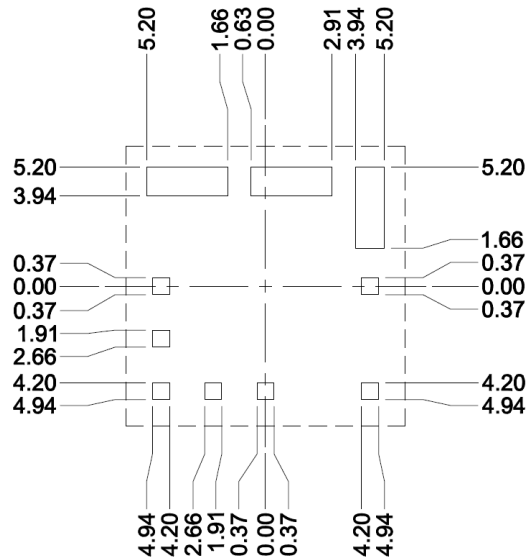

TOP VIEW

STENCIL PATTERN WITH SQUARE PADS (STENCIL  $t=120 \mu\text{m}$ )

# HP2403

## High Efficiency DC\DC Power Module

### MARKING DRAWING:

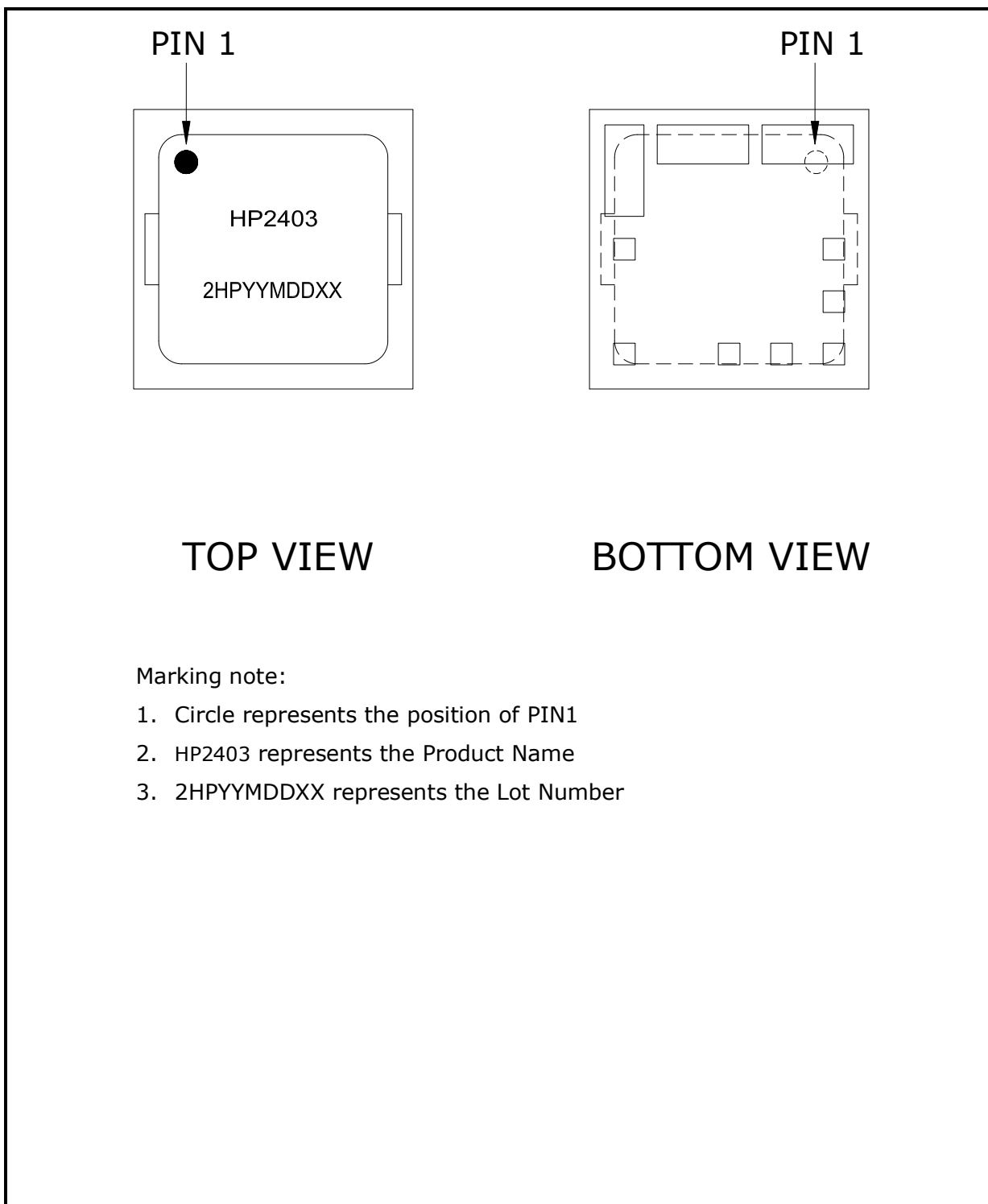

# HP2403

## High Efficiency DC\DC Power Module

### PACKING INFORMATION:

Unit: mm

#### PACKAGE IN TAPE LOADING ORIENTATION

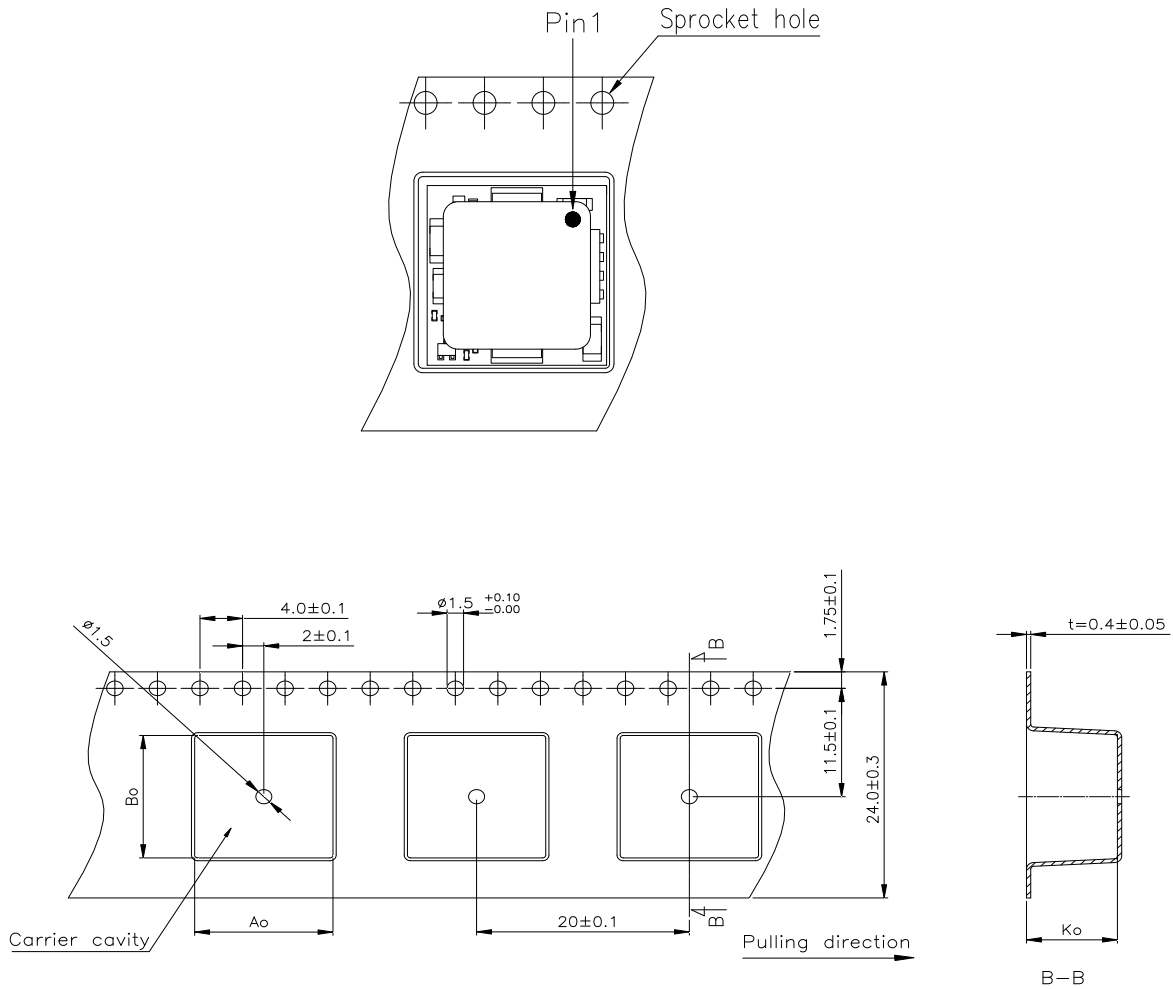

#### TAPE DIMENSION

A0	$13 \pm 0.10$
B0	$13 \pm 0.10$
K0	$8.55 \pm 0.10$

# HP2403

## High Efficiency DC\DC Power Module

### PACKING INFORMATION: (Cont.)

Unit: mm

#### Reel Dimension

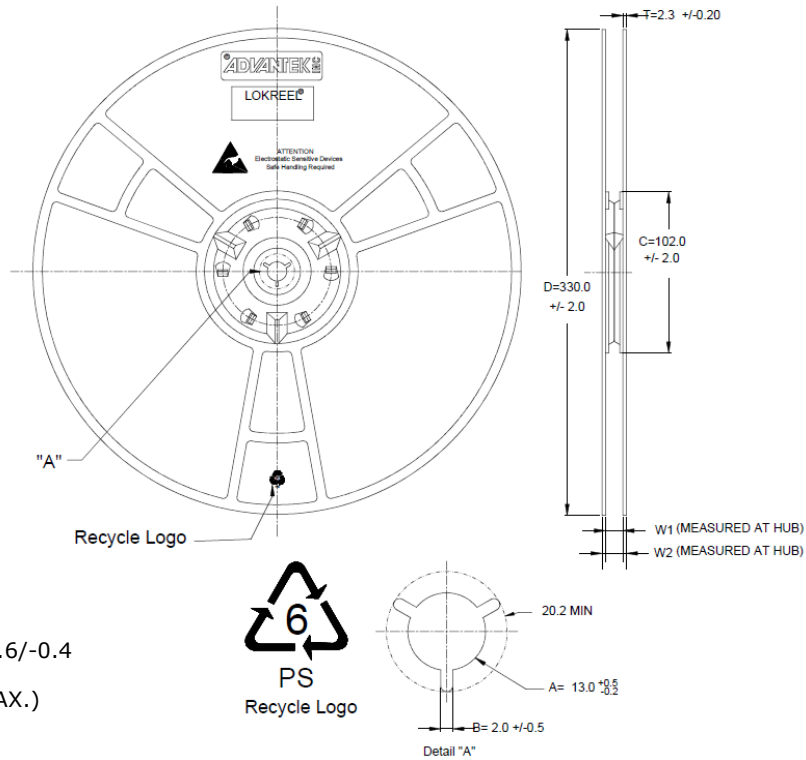

#### Peel Strength of Top Cover Tape

The peel speed shall be about 300mm/min.

The peel force of top cover tape shall be between 0.1N to 1.3N

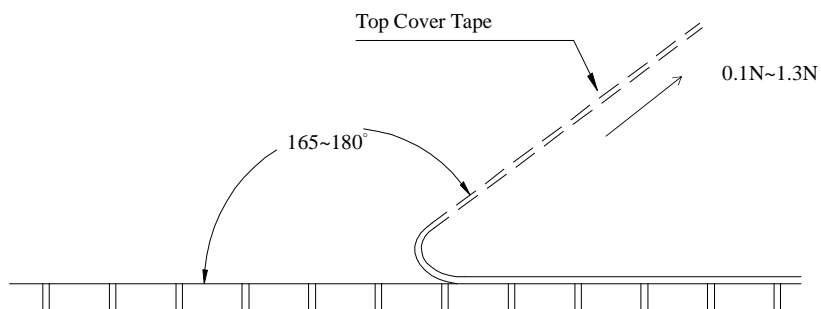

# HP2403

## High Efficiency DC\DC Power Module

### REVERSION HISTORY:

Date	Revision	Changes
2014.01.10	00	Release the preliminary specification.
2014.10.24	01	Adding POD, packing information.
2014.12.05	02	Change output range, adding pinout description and test condition information.
2014.12.17	03	PACKAGE OUTLINE DRAWING ● END VIEW Hmax. 8.4 -> 8±0.4
2015.01.06	04	Add MARKING DRAWING
2015.02.04	05	PACKING INFORMATION PIN 1 · Top left corner -> Top right corner
2015.02.26	06	1. Thermal Considerations: ● Add Thermal Considerations ● Add Case Temperature Sensing Point 2. PACKAGE OUTLINE DRAWING ● Tolerances:±0.2mm -> General Tolerances:±0.2mm ● Modify Drawing 3. LAND PATTERN REFERENCE ● Add General Tolerances ±0.2mm ● Modify Drawing 4. Update electrical specifications and applications information
2015.04.24	07	1. Change MSL level from level 2a to level 2 2. Change Output voltage set point tolerance from ±2% to ±1% and added output ripple and dynamic characteristics MAX values
2015.05.22	08	1. Change MSL level from level 2 to level 2a